

NOTICE

This device complies with part 15 of the FCC Rules. Operation is subject to the following two condition: (1) This device may not cause harmful interface, and (2) This device must accept any interface received, including Interface that may cause undesired operation.

This equipment has been tested and found comply with the limits for a Class A digital device, pursuant to part 15 of the FCC Rules. These limits are designed to provide reasonable protection against harmful interface when the equipment is operated in a commercial environment. This equipment generates, uses, and can radiate radio frequency energy and, if not installed and used in accordance with the instruction manual, may cause harmful interface to radio communications. Operation of this equipment in a residential area is likely to cause harmful interface in which case the user will be required to correct the interface at his own expense.

- ☛ All brand and trademark are belonged to their respective owner.
- ☛ Specifications are subject changed without notice.

Version:2010-1D-01

Index

1 Introduction	4
Installation.....	4
Recommended Steps.....	4
Configuration Flowchart.....	5
String Output Flowchart.....	5
Default Setting.....	6
Manual Label Layout.....	7
Frequent Question.....	8
2 Interface	10
Host Interface.....	10
Keyboard.....	11
RS-232.....	15
3 System Control	19
4 Code Option	26
UPC-A.....	26
UPC-E.....	28
EAN-13 (ISBN/ISSN).....	30
EAN-8.....	32
CODE-39.....	34
Interleaved 2 of 5 (Odd S-code).....	37
Industrial 2 of 5.....	39
Matrix 2 of 5.....	41
Codabar/NW7.....	43
Code-128.....	46
Code-93.....	48
Code-11.....	50
MSI/Plessey.....	52
UK/Plessey.....	54
Telepen.....	56
RSS14.....	58
RSS14 Limited.....	60
RSS14 Stacked.....	62
RSS Expansion.....	64
RSS Expansion Stacked.....	66
5 String Format	68
Preamble/Postamble.....	68
Prefix/Suffix.....	69
6 Memory	70
7 Bluetooth	74
8 Wireless	76
9 Special Setting for CM500 series	78
10 Cable Type	79
11 Test Chart	80
12 ASCII Code/Hexdecimal Table	82

Installation

- 1) First of all, you must make sure that the power is disconnected from your equipment before connecting the scanner. Beside, you also have to check the cable connector of the scanner match your equipment interface correctly.
 - 2) Boot up your computer after connecting the scanner with your equipment, the scanner will make a long music and light the LED, above scanner to indicate a successful power on. Trigger the button, the scan line in front of scanner will active. Now you can start to set programming optimal usage.
- ☛ If any of the above operation is not right, turn off the power immediately and check any improper connections. Go through all above steps again.

Recommended Steps

When the required settings have been configured, all settings are stored in non volatile memory of scanner after reading **End** label. There are recommended steps as follows.

- 1) Set right host interface for your scanner at **□10**.
(The scanner is in factory default as bold label)
- 2) Set interface to optimize protocol of scanner with your host in Chapter 2.
- 3) Set system control of scanner, such as specific adjustments double confirm, power saving, indicator and scanning mode which you prefer usage in Chapter 3.
- 4) Set code option of scanner for your usage in Chapter 4. You must make sure to enable the symbology first, then Min./Max. code length, code ID checksum and truncate digits are also covered.
- 5) Set string format of the scanner, such as preamble, postamble, prefix, suffix, code ID and code name transmission for your application in Chapter 5.

☛ If any error step were processing, scanner will generate a 5 beeps as warning. You have to take care this matter and set correctly again.

☛ If it is still not work properly, please contact with dealer.

Configuration Flowchart

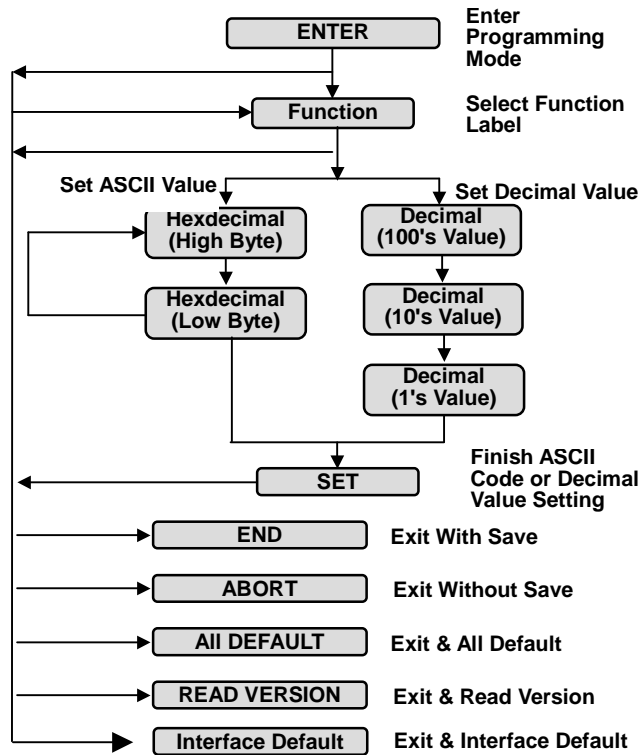

Introduction

String Output Flowchart

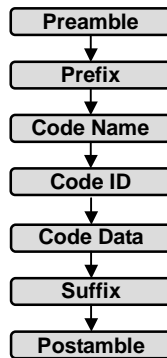

Default Setting

Code Type	Read Enable	Length		Truncate		Code ID
		Min.	Max.	Leading	Ending	
UPC-A	✓	-	-	0	0	A
UPC-E	✓	-	-	0	0	E
EAN-13	✓	-	-	0	0	F
EAN-8	✓	-	-	0	0	FF
Code-39	✓	0	0	0	0	M
Interleaved 2 of 5		4	0	0	0	I
Industrial 2 of 5		4	0	0	0	H
Matrix 2 of 5		4	0	0	0	G
Codabar/NW7	✓	0	0	0	0	N
Code-128	✓	0	0	0	0	K
Code-93		0	0	0	0	L
Code-11		0	0	0	0	O
MSI/Plessey		0	0	0	0	P
UK/Plessey		0	0	0	0	R
Telepen		0	0	0	0	S
RSS		0	0	0	0	T
RSS Limit		0	0	0	0	U
RSS Stack		0	0	0	0	V
RSS Expansion Limit		0	0	0	0	W
RSS Expansion Stack		0	0	0	0	X

Adjustment	Value	Result
Beep Loudness	05	Level 5
Beep Tone	27	2.4 Hz
Beep Duration	10	10 mSec
Stand-by Time	05	1 Sec
Led Off Delay	20	100 mSec
Lamp Off Delay	05	1000 mSec
Good read Time	05	100 mSec
Double Confirm Times	02	Once
Tx Gap	00	1 mSec
Tx Delay	00	10 mSec
Timeout	03	1 Sec
Wait Addon Count	10	Once
Preamble Data	00 ₁₆	<NULL>
Postamble Data	00 ₁₆	<NULL>
Prefix Data (All Datas)	00 ₁₆	<NULL>
Suffix Data (All Datas)	0D ₁₆ 0A ₁₆	<CR><LF>

Manual Label Layout

The scanner must be set by reading the barcode labels in manual. The description of label is as follows.

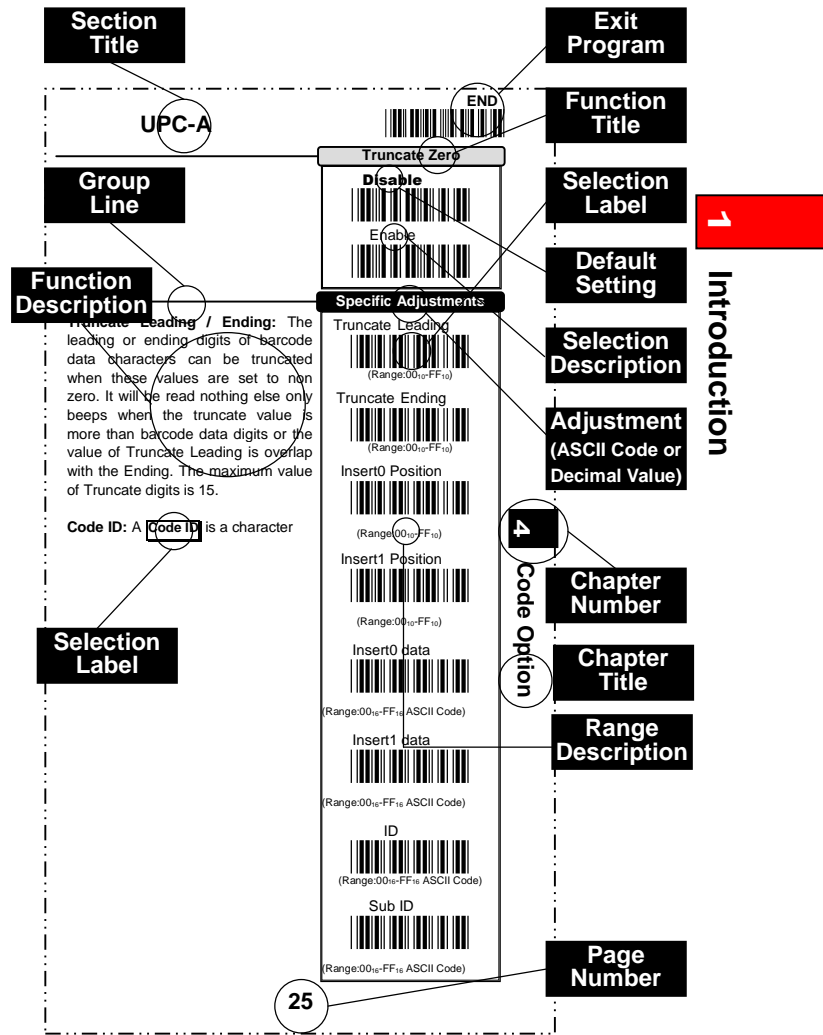

The factory default settings are indicated by bold symbols.

Frequent Question

Q: Why scanner block the keyboard operation?

A: Check the cable connection with your equipment, then turn power on again.

Q: If the scanner doesn't need an Enter character addition after each barcode label transmission.

A: Refer to postamble transmission at 1166, then set **Disable**.

Q: If the scanner needs to read single digit code.

A: Refer to Min. code length of code option use "01" in Chapter 4 for single code readable.

Q: If the scanner can't discriminate an unknown label, but read manual very well.

A: Refer to code name at 1120 to set **Enable**, read a barcode label, then you will know what symbology is read. Beside, it maybe need to verify checksum. Refer to verify checksum of code option in Chapter 4, and set **Enable**.

Q: If the scanner transferred characters very slow or lost some characters when data be output to screen by keyboard interface

A: You may set caps lock to be **Alt+Keypad** at 1111. Otherwise, it maybe mis-match of transmission rate, therefore, you can adjust an appropriate **Tx Gap** to match your equipment. See 1112.

Q: If the scanner only sounds beep when read barcode but didn't send data to PC.

A: It is the communication problem between scanner interface and PC. It may be caused by cable damaged or wrong interface setting. Check your cable connection and set the interface setting again.

Q: What does Tx , Tx Gap mean ?

A: Tx means transmission. Tx Gap means transmission of Inter-character delay. See 1112.

☛ Call to the dealer if scanner dose not work properly.

1

Introduction

ENTER



Host Interface

Type	
ODC1	Keyboard
ODC2	RS232

If the interface cable you have is PS2 or USB HID, please set as Keyboard. If it is USB COM or RS232 type, please set as RS232. .

Type	
ZADE	ALL DEFAULT
ZDEF	BARCODE DEFAULT
ZKBD	KEYBOARD DEFAULT
Z232	RS232 DEFAULT
ZVER	VERSION
ZEXT	ABORT
ZISP	ISP

All Default: All settings will be reset as bold label, but exclude interface setting.

Barcode Default: Restore to default barcode setting

Keyboard Default: Restore to keyboard interface default setting

RS232 Default: Restore to RS232 interface default setting

Version: You can get the firmware version & date of decoder.

ABORT: To skip or give up current configuration, so all previous setting will be aborted before you set **END** to finish programming.

ISP: After enable ISP, the scanner will become COM interface and can be update firmware or configuration to scanner.

☛ End user please don't update firmware by yourself, unless you get correct instruction from your dealer. Because improper procedure may cause damage on the scanner.

Keyboard

End

If select **Enable** means you use the usb hid,if select **Disable** means you use the ps2 cable.

It is recommended to **Enable** the function if your PC without keyboard installation. It simulates keyboard timing and pass keyboard present status to the PC during power-on.

The **Keypad** must be enable if your application program can accept numeric code from keypad only. The scanner will output code as numeric key-pad did when it read numeric digit.

By selecting **Caps Lock On** or **Caps Lock Off**, scanner can get Caps Lock status. If **Alt+Keypad** were selected, Caps Lock and output will be independent.The **Auto** function can be effect when USB HID or KB Simulation is enable.When you set **Auto**, the scanner will detect the status of Keyboard Caps Lock.So the batcode data outputwill follow the status of Keyboard Caps Lock.

Example Barcode "ABCdef"

The interface shows a vertical stack of menu items, each with a barcode and a selection box:

- USB**: Options are **Disable** (1A00) and **Enable** (1A01).
- Simulation**: Options are **Disable** (1A50) and **Enable** (1A51).
- Key Pad**: Options are **Disable** (1A70) and **Enable** (1A71).
- Caps Lock**: Options are **Auto** (1B80), **Alt+Keypad** (1B81), **Caps Lock Off** (1B82), and **Caps Lock On** (1B83).

2
Interface

Status Selection	Caps Lock On	Caps Lock Off
Caps Lock On	ABCdef	abcDEF
Caps Lock Off	abcDEF	ABCdef
Alt+Keypad	ABCdef	ABCdef

ENTER



Keyboard

Specific Adjustments

1052 Tx Gap
 (Range:00₁₀-FF₁₀ Unit:1ms)

1062 Tx Delay
 (Range:00₁₀-FF₁₀ Unit:10ms)

1072 Timeout
 (Range:01₁₀-FF₁₀ Unit:1000ms)

Tx Gap: It will delay the output timing of per digit. If the output speed is too high, the system may not receive all digits. If so, try out suitable delay time to make system work properly.

Tx Delay: It can be used while you will scan several continued short barcode or multi-filed barcode. This function will delay the timing after barcode.

It can delay the waiting time of serial scanner for the handshaking acknowledgment from the host PC. If scanner didn't get acknowledgment from host PC after timeout occur, the scanner will sound 5 beeps as warning. You may need to check the handsanking mode or adjust to longer delay timer. The function is particular useful for some applications which the host PC will take longer respond time

* **TX** means : **transmission**

Example Barcode Data: "ABCD" Tx Gap: **2ms**
 Tx Delay: **10ms**

- 1) **ENTER** → Entry Programming
- 2) **Tx Gap** → 0 → 2 → **SET** → 2ms Inter-char. Delay
 02*1ms(Unit)=2ms
- 3) **Tx Delay** → 0 → 1 → **SET** → 10ms Transmit Delay
 01*10ms(Unit)=10ms
- 4) **END** Exit Programming

Output

A	2ms	B	2ms	C	2ms	D	2ms	10ms
---	-----	---	-----	---	-----	---	-----	------

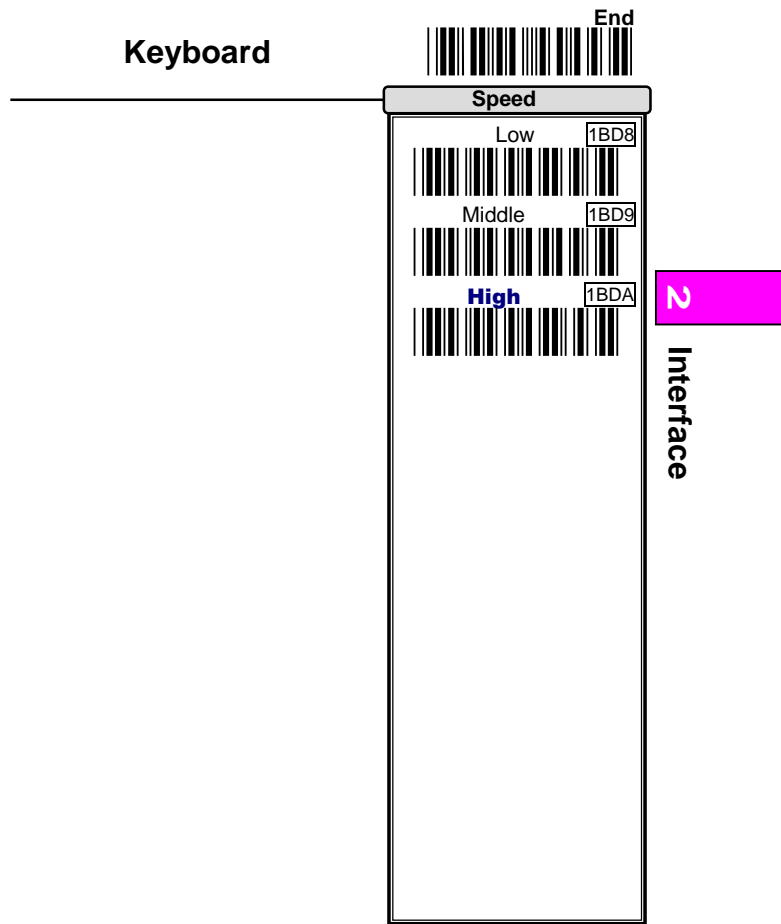

ENTER



Keyboard

Layout	
1DC0	USA (US)
1DC1	UK (UK)
1DC2	Japan
1DC3	France (FR)
1DC4	Germany (GR)
1DC5	Italian (IT)
1DC6	Spanish (SP)
1DC7	Portuguese (PO)

Here you can set up the scanner's language to match your computer keyboard layout.

RS232

If the scanner is with USB cable but virtual COM interface, it should be programmed as **USB COM enable**, otherwise, the data will not be output to the PC.

CTS: Clear To Send (Hardware Signal)
RTS: Request To Send (Hardware Signal)
Xon: Transmit On (ASCII Code 13₁₆)
Xoff: Transmit Off (ASCII Code 11₁₆)

None: It only uses TxD and RxD signal without relation for any hardware or software handshaking protocol.

RTS/CTS (CTS/RTS): If the scanner sent barcode data to host computer, it will issue the signal of RTS (CTS) first, and wait for the signal returned from the host computer. Then it will perform the normal data communication. If there is no CTS (RTS) signal returned from the host computer after timeout (Response Delay), the scanner will sound 5 beeps as warning.

Scanner Ready: The scanner will issue signal of RTS after power-on, then transmit data upon receiving active CTS signal.

Data Ready: The scanner will issue signal of RTS to indicate a successful decoding and will transmit data upon receiving CTS signals.

Xon/Xoff: When the host PC can't accept data, it will notice the scanner to suspend data transmission by sending an Xoff code, and Xon as to be continued.

☛ **Remark :** If the interface is USB COM, it does not support **Protocol** setting.



USB COM

Disable 2A00



Enable 2A01



Protocol

None 2CC0



RTS/CTS 2CC1



CTS/RTS 2CC2



Scanner Ready 2CC3



Data Ready 2CC4



Xon/Xoff 2CC5



2

Interface

ENTER



RS232

Baud Rate

2BDC	115200 Bps
2BDB	57600 Bps
2BDA	38400 Bps
2BD9	19200 Bps
2BD8	9600 Bps
2BD7	4800 Bps
2BD6	2400 Bps
2BD5	1200 Bps
2BD4	600 Bps
2BD3	300 Bps

Data Bits

2A60	7 Bits
2A61	8 Bits

Stop Bits

2A70	1 Bits
2A71	2 Bits

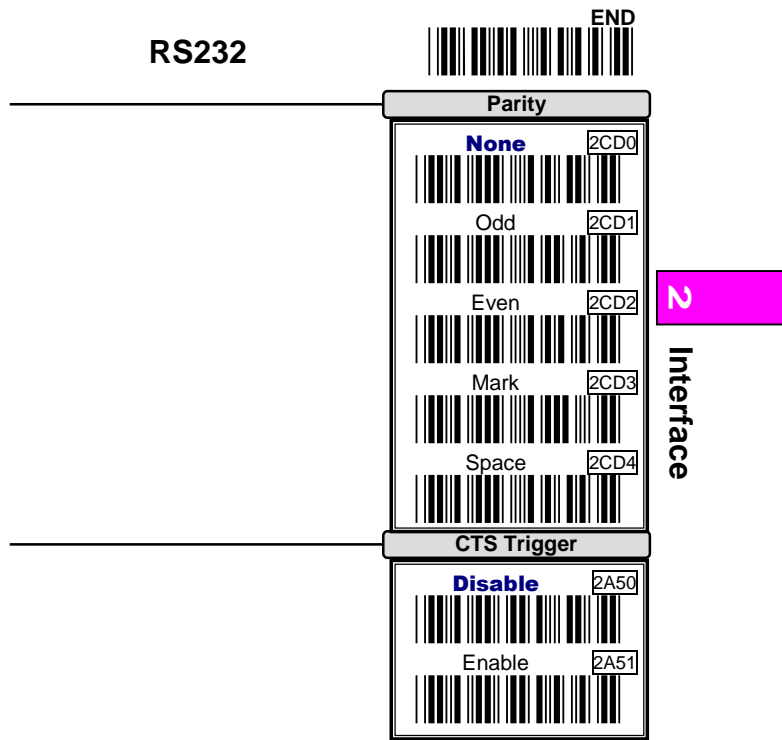

ENTER



RS232

Specific Adjustments

2052	Tx Gap
(Range:00 ₁₀ -FF ₁₀ Unit:1ms)	
2062	Tx Delay
(Range:00 ₁₀ -FF ₁₀ Unit:10ms)	
2072	Timeout
(Range:01 ₁₀ -FF ₁₀ Unit:1000ms)	

Tx Gap: It will delay the output timing of per digit . It is same as **Tx Gap** of keyboard wedge on 12.

Tx Delay: It is a delay time after barcode. It is same as **Tx Delay** of Keyboard wedge on 12.

Timeout: It is same as **Timeout** of Keyboard wedge on 12.

System Control

END



<p>The power-on music will indicate the scanner as successful power on. It can be inhibited by setting Disable.</p>	<p>Power on Music</p> <p>Disable 0A40</p> <p>Enable 0A41</p>
<p>The scanner can be activated LED light source without trigger pushed by setting Enable.</p>	<p>Power on Trigger</p> <p>Disable 0A50</p> <p>Enable 0A51</p>
<p>The scanner will sound a beep for per successful barcode reading when it is set Enable. And the beep Volume, Tone and Time can be adjusted by setting on 23.</p>	<p>Good read Beep</p> <p>Disable 8B00</p> <p>Enable 8B01</p>
<p>If set Enable, the Scanner Vibrates when successfully read a barcode. This function is only applicable in CM 200 series. For CM 500 series, vibration motor is an extra purchase option.</p>	<p>Good read Vibrator</p> <p>Disable 8B20</p> <p>Enable 8B21</p>
<p>If set Enable, the same barcode will not be scanned. But this function only work under Continue Mode.</p>	<p>Reject Same</p> <p>Disable 8B60</p> <p>Enable 8B61</p>
<p>This is auto sensor function. So even the LED is off, but when object or barcode under the scan range, it will be auto LED on and scan barcode by set Enable. This function is only applicable in CM003, CM008, CM300 and CM 1002 series.</p>	<p>Object Detect</p> <p>Disable 0A60</p> <p>Enable 0A61</p>



System Control

ENTER



System Control

Tx Length

8C50 **Disable**

8C51 Enable

If your application need Barcode Length, you must set this function to be **Enable**.

Force Case

8E80 **None**

8E81 Inverse

8E82 Lowercase

8E83 Uppercase

It will converse all output digits to be same printing-case, even one barcode may have two kinds of case.

Example Barcode "BarCode",

Uppercase	BARCODE
Lowercase	barcode

Double Confirm

8B70 **Disable**

8B71 Enable

When barcode is easy misreading, try this function. Then scanner will output the data after same decoding by double times. For more times confirm, please refer **Double Confirm Count** on 24. But double confirm will delay the scan speed.

Tx Code ID

8C30 **Disable**

8C31 Enable

If your application need Code ID, you must set this function to be **Enable**.

Code ID Position

8C20 **Before Code Data**

8C21 After Code Data

Upon your usage, the output position of Code ID can be **Before** or **After Code Data** by setting.

System Control

If you want the control code to be output, then set it as **Enable**.

This function can show unknown barcode type which is readable by this scanner. When **Enable** is set, Code Name will be showed on front of per barcode, then you will know what kind of barcode symbology it is.

This Function is only applicable in CM301, CM-302 and CM901 with **special designed Barcode Scanner Holder**.

Enable: When placing the barcode scanner on the holder, enable this function will turn off the LED beam light in any scanning mode, if the scanner has been preset the scanning mode as "auto detect". Auto detect function stays the same.

With auto Trigger: When "With Auto trigger" is activated, the scanner LED beam light will automatically turn on when taking off the scanner from the holder. The scanning mode can be implement with this function except "**Momentary**" mode.

Note: This function is only applicable in CM301, CM 302 and CM901 model with special designed barcode scanner holder. and these are optional extra purchase function and items.



Tx Control Code

Disable 8C40



Enable 8C41



Tx Code Name

Disable 8C00



Enable 8C01



Return Detect

Disable 0B80



Enable 0B81



With Auto Trigger 0B82



3

System Control

ENTER



System Control

Scanning Mode	
8AC2	Good read Off
8AC4	Momentary
8AC5	Alternate
8AC3	Timeout Off
8AC6	Timeout Flash
8AC1	Continue
8AC0	Test

Good read Off: The LED light source will be on when the trigger is pushed and then be off when a barcode is read successfully. And you can refer **Stand-by Time** on 23.

Momentary: The trigger will act as a switch. When the trigger is pressed, it will scan barcode, when it is released it will stop to scan.

Alternate: The trigger will be act as a toggle switch. Press button to active or stop scanning.

Timeout Off: The scanner will scan barcode when trigger is pressed, and it will stop scanning when barcode is not decoded after stand-by time elapsed. **Stand-by Time** setting is on 23.

TimeOut Flash: The scanner will scan barcode when trigger is pressed, Light source turns flashing when barcode is not decoded after stand-by time elapsed. **Stand-by Time** setting is on 23. This function is only applicable in CM-003 series.

Continue: No need to press the trigger then the scanner can read barcode when the LED light source is on.

Test: The scanner will always keep reading continuously and same barcode reading is allowed without double confirm. The feature can test the performance of scan speed and sensitive.

☛ For saving power and keeping longer life of laser component, the laser beam and motor will be stopped when no code is decoded for all above scanning mode .

System Control

END

Specific Adjustments

Beep Adjustments: You can adjust **Beep Volume**, **Beep Tone** and **Beep Time** of good reading upon your favorite usage.

Stand-by Time: The timeout duration can be adjusted from 1 to 99 seconds. The **Stand-by Time** is only effective during **Good-read Off** & **Timeout Off** mode for CCD scanner. If no code to be read after **Stand-by Time**, on laser scanner, the laser beam and motor will be shutdown to keep the life time of laser diode.

LED/Lamp Off Delay: There are two kinds LED light source durations for all scanning mode. The scanner light source will be flash when no code is read until **Standby Time** is timeout. The **Led Off Delay** is lighting duration and the **Lamp Off Delay** is blanking duration. The scanner can still read barcode during the light source is flashing and then be waked up automatically when read a barcode.

Object Detec Level : It is the function of auto detection. You can set up the level of detection sensitivity you want.

Object Detect Time : It can adjust the time for auto detection duration.

Setup Timeout : It is the timer between scanner go into "Enter" and quit "End". So that means you need to finish whole setting before the **setup timeout** timing. Otherwise, the scanner will quit the setting mode as soon as the time is up.

Beep Volume	8142
(Range:00 ₁₀ -10 ₁₀ Unit:Level)	
Beep Tone	8162
(Range:00 ₁₀ -50 ₁₀ Unit:100Hz)	
Beep Time	8152
(Range:00 ₁₀ -FF ₁₀ Unit:10ms)	
Standby Time	8122
(Range:00 ₁₀ -FF ₁₀ Unit:1s)	
LED Off Delay	8192
(Range:00 ₁₀ -FF ₁₀ Unit:10ms)	
Lamp off Delay	8172
(Range:00 ₁₀ -FF ₁₀ Unit:1s)	
Good read Time	8112
(Range:00 ₁₀ -FF ₁₀ Unit:100ms)	
Object Detect level	0052
(Range:00 ₁₀ -FF ₁₀)	
Object Detect Time	0062
(Range:00 ₁₀ -FF ₁₀ Unit:100ms)	
Setup Timeout	0072
(Range:00 ₁₀ -FF ₁₀ Unit:1000ms)	



System Control

ENTER



System Control

Specific Adjustments

81A2 Vibrator Off Delay



(Range:00₁₀-FF₁₀ Unit:10ms)

8132 Wait Addon Count



(Range:00₁₀-FF₁₀)

8102 Double Confirm
count



(Range:00₁₀-FF₁₀)

81E2 Global Min. Length



(Range:00₁₀-FF₁₀)

81F2 Global Max. Length



(Range:00₁₀-FF₁₀)

ZCLK Set Date & Time



Vibrator Off Delay: Sets the duration of vibration of scanner, Unit: 10 ms.

Wait Addon Count: This setting is used for WPC add-on code, such as EAN and UPC. The WPC code must be decoded first, then Add-on. Add-on may not be decoded with WPC at the same time. Therefore, you can set **wait addon count** to force the add-on code must be output with WPC code together.

If the Wait addon count is set as "0", the barcode data will only be output with add-on code.

Double Confirm Count: The more confirm times the less miss-reading will be happened. This feature should depend on the symbology and printing quality of barcodes. Selecting a higher value will reduce read-out speed.

Global Min. / Max. Length: When you set min. length, barcode digits number which is under the min. length, it will not be decoded. If you set Max. length, the barcode digits which is over the value will not be decoded, neither. But the values setting will not effect in some fixed length symbologies (i.e. UPC and EAN is called WPC).

If Min. Length and Max Length are specified, and Min.length > Max. Length, the barcode data will only decoded by the length of two specified value of Min. Length and Max. Length.

Set Date & Time: Date and Time setting. The setting format will be (yy/mm/dd/hh/mm/). For the example, setting the scanner date and time as 2012, Aug, 30, 13:30. (**Note: this function is only applicable in CM200 and CM500 series**).

Procedure:

- 1) Scan "Enter" barcode
- 2) Scan "Set Date & time" barcode
- 3) Refer to ASCII table in page 82, and scan 1208301330.as (2012, Aug, 30, 13:30)
- 4) Scan "SET" barcode
- 5) Scan "End" barcode

System Control



3

System Control

ENTER



UPC-A

Read

AA70 Disable

AA71 **Enable**

Format

Leading Zero	Data Digits (11 Digits)	Check Digit
--------------	-------------------------	-------------

Addon Type

AB90 **None**

AB91 Addon 2

AB92 Addon 5

AB93 Addon 2+5

The Add-on barcode is the supplemental 2 or 5 digits for WPC code.

Format

Leading Zero	Data Digits (11 Digits)	Check Digit	Add-on 2 or 5
--------------	-------------------------	-------------	---------------

Wait Addon

AA00 **Disable**

AA01 Enable

It is recommended to set **Enable** if you want the UPC can be output with add-on code together. Please enable this function first and refer **Wait Addon Count** at 24 for good reading of Add-on code.

Tx Chksum

AA60 Disable

AA61 **Enable**

By setting **Enable**, check characters will be transmitted.

UPC-A

END



The all leading "0" of barcode data will be truncated when this function is enabled.

Example Barcode "00054321"

Output "54321"

Truncate Zero

Disable AA50

Enable AA51

Truncate Lead / End: The leading or ending character of barcode data will be truncated when these values are set to non zero. It will be output nothing except beeps if the truncate value is more than barcode data digits or overlap with the Ending. The maximum value of Truncate digits is 15.

ID: The **[D]** is a character which is used to represent the symbology while successful reading. It will be prefixed on the front or back barcode. There are some symbologies (i.e. UPC-E and EAN-8) include 2 Code ID. If your application need Code ID, please enable Code ID Transmission first. You can refer the setting at **[20]**.

Insert Position & Data : This function can append one or two characters into the barcode data. But you need to make sure the value of insert position can not be greater than the length of barcode. Otherwise, your setting will be no effect. You can add an Insert Data 0 at Insert Position 0

Specific Adjustments

Truncate Lead A082

(Range:00₁₀-FF₁₀)

Truncate End A092

(Range:00₁₀-FF₁₀)

Insert0 Position A0C2

(Range:00₁₀-FF₁₀)

Insert1 Position A0D2

(Range:00₁₀-FF₁₀)

Insert0 Data A0E2

(Range:00₁₆-FF₁₆ ASCII Code)

Insert1 Data A102

(Range:00₁₆-FF₁₆ ASCII Code)

ID A122

(Range:00₁₆-FF₁₆ ASCII Code)

Sub ID A142

(Range:00₁₆-FF₁₆ ASCII Code)

4

Code Option

☛ If the insert position you set is 0, the character will be inserted in the front of the barcode. If the value is FF, the inserted position will be behind the barcode. If the value is 1, the character will be inserted behind the first barcode digit. If the value is 2, the character will be inserted behind the second digit.....and so forth.

ENTER



UPC-E

Read

BA70 Disable

BA70 **Enable**

Format

Leading Zero	Data Digits (6 Digits)	Check Digit
--------------	------------------------	-------------

Add-on

BB90 **None**

BB91 Addon 2

BB92 Addon 5

BB93 Addon 2+5

Format

Leading Zero	Data Digits (6 Digits)	Check Digit	Add-on 2 or 5
--------------	------------------------	-------------	---------------

Wait Addon

BA00 **Disable**

BA01 Enable

Refer 26.

Expansion

BA10 **Disable**

BA11 Enable

This expansion function is for UPC-E and EAN-8 only. It will extend the barcode to be 13-digits by "0" zero. .

Example Barcode "01236547"

Output "001236000057"

Tx CheckSum

BA60 Disable

BA61 **Enable**

Refer 26.

UPC-E

END



Refer 27.

Truncate Zero

Disable BA50



Enable BA51



Refer 27.

Truncate Zero

Truncate Lead B082



(Range:00₁₀-FF₁₀)

Truncate End B092



(Range:00₁₀-FF₁₀)

Insert0 Position B0C2



(Range:00₁₀-FF₁₀)

Insert1 Position B0D2



(Range:00₁₀-FF₁₀)

Insert0 Data B0EB



(Range:00₁₆-FF₁₆ ASCII Code)

Insert1 Data B10B



(Range:00₁₆-FF₁₆ ASCII Code)

ID B12B



(Range:00₁₆-FF₁₆ ASCII Code)

Sub ID B14B



(Range:00₁₆-FF₁₆ ASCII Code)

4

Code Option

ENTER



EAN-13

Read	
CA70	Disable
CA71	Enable

Format

Data Digits (12 Digits)	Check Digit
----------------------------	----------------

Addon type	
CB90	None
CB91	Addon 2
CB92	Addon 5
CB93	Addon 2+5

Format

Data Digits (12 Digits)	Check Digit	Add-on 2 or 5
----------------------------	----------------	------------------

Wait Addon	
CA00	Disable
CA01	Enable

Refer 26.

ISBN/ISSN Conversion	
CA10	Disable
CA11	Enable

The ISBN (International Standard Book Number) and ISSN (International Standard Serial Number) are especial barcode for book and magazine. The ISBN is 10 digits with leading "978" and the ISSN is 8 digits with leading "977" of "EAN-13" .

Example Barcode "978957222720"

Output "957222724"

Example Barcode "9771019248004"

Output "10192484"

EAN-13

END



Refer 26.

Tx Chksum

Disable CA60



Enable CA610



Refer 27.

Truncate Zero

Disable CA50



Enable CA51



Refer 27.

Specific Adjustments

Truncate Lead C082



(Range:00₁₀-FF₁₀)

Truncate End C092



(Range:00₁₀-FF)

Insert0 Position C0C2



(Range:00₁₀-FF)

Insert1 Position C0D2



(Range:00₁₀-FF)

Insert0 Data C0EB



(Range:00₁₆-FF₁₆ ASCII Code)

Insert1 Data C10B



(Range:00₁₆-FF₁₆ ASCII Code)

ID C12B



(Range:00₁₆-FF₁₆ ASCII Code)

Sub ID C14B



(Range:00₁₆-FF₁₆ ASCII Code)

4

Code Option

ENTER



EAN-8

Read

DA70 Disable

DA71 **Enable**

Format

Data Digits (7 Digits)	Check Digit
---------------------------	----------------

Addon Type

DB90 **None**

DB91 Addon 2

DB92 Addon 5

DB93 Addon 2+ 5

Format

Data Digits (7 Digits)	Check Digit	Add-on 2 or 5
---------------------------	----------------	------------------

Wait Addon

DA00 **Disable**

DA01 Enable

Refer 26.

Expansion

DA10 **Disable**

DA11 Enable

Refer 26.

Truncate Zero

DA50 **Disable**

DA51 Enable

Refer 27.

EAN-8

END



Refer 26.

Tx Chksum

Disable DA60



Enable DA61



Refer 27.

Specific Adjustments

Truncate Lead D082



(Range:00₁₀-FF)

Truncate End D092



(Range:00₁₀-FF)

Insert0 Position D0C2



(Range:00₁₀-FF)

Insert1 Position D0D2



(Range:00₁₀-FF)

Insert0 Data D0EB



(Range:00₁₆-FF₁₆ ASCII Code)

Insert1 Data D10B



(Range:00₁₆-FF₁₆ ASCII Code)

ID D12B



(Range:00₁₆-FF₁₆ ASCII Code)

Sub ID D14B



(Range:00₁₆-FF₁₆ ASCII Code)

4

Code Option



CODE-39

Read

EA70 Disable

EA71 **Enable**

Format

Start	Data Digits	Checksum	End
"*"	(Variable)	(Optional)	"*"

Type

EB90 **Standard**

EB91 Full ASCII

The **Full ASCII** function is an enhanced setting for Code-39 which is with total 128 digits to represent **Full ASCII** code. It must be combined by either one of + , % , \$ or / and one of alpha character (A to Z).

Format

EBA0 **None**

EBA1 Code-32

EBA2 Code-32 with 'A'

The Code-32 symbology (Italian Pharmaceutical) is another version of Code-39 which max. can be 10 digits and can be 0 – 9 digits. The leading A is an optional character and can be set to be transmitted or not.

Tx Start/End

EA20 **Disable**

EA21 Enable

The Start and End character of Code-39 must be "*". You can transmit all data digits including two "*" by set **Enable**.

Truncate Zero

EA50 **Disable**

EA51 Enable

Refer [□27](#).

CODE-39



The checksum of Code-39 is optional and it is made the sum module 43 as the numerical value of the data digits.

Verify Checksum

Disable EBB0

Enable EBB1

By setting **Enable**, checksum will be transmitted.

Tx Checksum

Disable EA60

Enable EA61

Min. / Max. Code Length: Each symbology has its own Min./Max. Code Length. They can be set to qualify data entry. If the Min./Max. Code Length is zero, the Public Min./Max. Code Length will be changed. The length is defined by the actual barcode length transmitted. If the barcode length is over the value of min/max. length, it will not be output. Make sure the Minimum length value is not bigger than the Maximum length, otherwise, this barcode will not be output. In particular, you can set the same value for Minimum and Maximum length to have the fixed length barcode must be decoded.

Refer 27.

Specific Adjustments

Truncate Lead E0B2

(Range:00₁₀-FF)

Truncate End E092

(Range:00₁₀-FF)

Min. Length E0A

(Range:01₁₀-FF)

Max. Length E0B2

(Range:01₁₀-FF)

Insert0 Position E0C2

(Range:01₁₀-FF)

Insert1 Position E0D2

(Range:01₁₀-FF)



Code Option

ENTER



CODE-39

Specific Adjustments

Refer  27.

E0DB	Insert0 Data
(Range:00 ₁₆ -FF ₁₆ ASCII Code)	
E10B	Insert1 Data
(Range:00 ₁₆ -FF ₁₆ ASCII Code)	
E12B	Code ID
(Range:00 ₁₆ -FF ₁₆ ASCII Code)	
E14B	Code-32 ID
(Range:00 ₁₆ -FF ₁₆ ASCII Code)	

Interleaved 2 of 5

END

Format

Data Digits (Variable)	Checksum (Optional)
---------------------------	------------------------

The checksum is made the sum module 10 as the numerical values of all data digits.

Refer 26.

Refer 27.

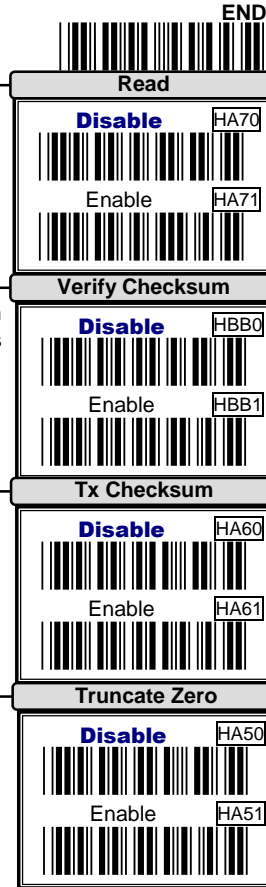

4

Code Option

ENTER



Interleaved 2 of 5

Specific Adjustments

H082	Truncate Lead	
	(Range:00 ₁₀ -FF)	
H092	Truncate End	
	(Range:00 ₁₀ -FF)	
H0A2	Min. Length	
	(Range:00 ₁₀ -FF)	
H0B2	Max. Length	
	(Range:00 ₁₀ -FF)	
H0C2	Insert0 Position	
	(Range:00 ₁₀ -FF)	
H0D2	Insert1 Positionh	
	(Range:00 ₁₀ -FF)	
H0EB	Insert0 Data	
	(Range:00 ₁₆ -FF ₁₆ ASCII Code)	
H10B	Insert1 Data	
	(Range:00 ₁₆ -FF ₁₆ ASCII Code)	
H12B	ID	
	(Range:00 ₁₆ -FF ₁₆ ASCII Code)	
H14B	Sub ID	
	(Range:00 ₁₆ -FF ₁₆ ASCII Code)	

Because, the start and end of interleaved 2 of 5 code is not only one pattern in symbol. In order to prevent partial reading, it is recommended to use the fixed code length for each 2 of 5 code barcode label. Setting the same **Min./Max. Code Length**, it is like a length filter, and only one length is accepted.

Refer 27 & 35.

Industrial 2 of 5

END

Format

Data Digits (Variable)	Checksum (Optional)
---------------------------	------------------------

Read

Disable [A70]



Enable [A71]



Refer  27.

Truncate Zero

Disable [A50]



Enable [A51]



Refer  26.

Tx Checksum

Disable [A60]



Enable [A61]



The checksum is made the sum module 10 as the numerical values of all data digits.

Verify Checksum

Disable [BB0]



Enable [BB1]



4

Code Option

ENTER



Industrial 2 of 5

Specific Adjustments

Refer 27, 35.

1082 Truncate Lead



(Range:00₁₀-FF)

1092 Truncate End



(Range:00₁₀-FF)

10A Min. Length



(Range:00₁₀-FF)

10B2 Max. Length



(Range:00₁₀-FF)

10C2 Insert0 Position



(Range:00₁₀-FF)

10D2 Insert1 Positionh



(Range:00₁₀-FF)

10EB Insert0 Data



(Range:00₁₆-FF₁₆ ASCII Code)

110B Insert1 Data



(Range:00₁₆-FF₁₆ ASCII Code)

112B ID



(Range:00₁₆-FF₁₆ ASCII Code)

114B Sub ID



(Range:00₁₆-FF₁₆ ASCII Code)

Matrix 2 of 5

END

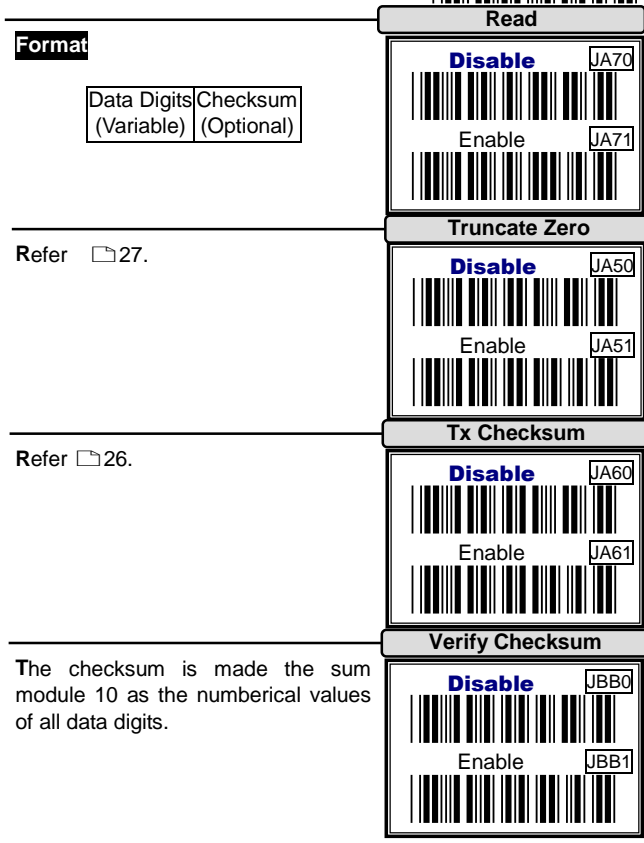

Format

Data Digits (Variable)	Checksum (Optional)
---------------------------	------------------------

Refer 27.

Refer 26.

The checksum is made the sum module 10 as the numerical values of all data digits.

4

Code Option

ENTER



Matrix 2 of 5

Specific Adjustments

Refer 27 35.

J082	Truncate Lead		(Range:00 ₁₀ -FF ₁₀)
J092	Truncate End		(Range:00 ₁₀ -FF ₁₀)
J0A2	Min. Length		(Range:00 ₁₀ -FF ₁₀)
J0B2	Max. Length		(Range:00 ₁₀ -FF ₁₀)
J0C2	Insert0 Position		(Range:00 ₁₀ -FF ₁₀)
J0D2	Insert1 Positionh		(Range:00 ₁₀ -FF ₁₀)
J0EB	Insert0 Data		(Range:00 ₁₆ -FF ₁₆ ASCII Code)
J10E	Insert1 Data		(Range:00 ₁₆ -FF ₁₆ ASCII Code)
J12E	ID		(Range:00 ₁₆ -FF ₁₆ ASCII Code)
J14E	Sub ID		(Range:00 ₁₆ -FF ₁₆ ASCII Code)

Codabar/NW7

END

Format			
Start	Data Digits (Variable)	Checksum (Optional)	End

The Codabar has four kinds of Start/End patten, you may choice one to match your application.

Sometimes, the Codabar requires only same Start/End patten can be decoded.

You can transmit all data digits including Start/End by set Enable.

The checksum is made as the sum module 16 of the numerical values of all data digits.



Read	
Disable	GA70
Enable	GA71

Type	
ABCD/ABCD	GB90
abcd/abcd	GB91
ABCD/TN*E	GB92
abcd/tn*e	GB93

Same Start/End Pair	
Disable	GA00
Enable	GA01

Tx Start/End	
Disable	GA20
Enable	GA21

Verify Checksum	
Disable	GBB0
Enable	GBB1

4

Code Option

ENTER



Codabar/NW7

Tx Checksum

GA60	Disable
GA61	Enable

Refer 26.

Truncate Zero

GA50	Disable
GA51	Enable

Refer 27.

Codabar/NW7

END



Refer 27, 35.

Specific Adjustments

Truncate Lead	G082
(Range:00 ₁₀ -FF ₁₀)	
Truncate End	G092
(Range:00 ₁₀ -FF ₁₀)	
Min. Length	G0A2
(Range:00 ₁₀ -FF ₁₀)	
Max. Length	G0B2
(Range:00 ₁₀ -FF ₁₀)	
Insert0 Position	G0C2
(Range:00 ₁₀ -FF ₁₀)	
Insert1 Positionh	G0D2
(Range:00 ₁₀ -FF ₁₀)	
Insert0 Data	G0EB
(Range:00 ₁₆ -FF ₁₆ ASCII Code)	
Insert1 Data	G10B
(Range:00 ₁₆ -FF ₁₆ ASCII Code)	
ID	G12B
(Range:00 ₁₆ -FF ₁₆ ASCII Code)	
Sub ID	G14B
(Range:00 ₁₆ -FF ₁₆ ASCII Code)	

4

Code Option

ENTER



Code-128

Read

FA70 Disable

FA71 **Enable**

Format

Data Digits (Variable)	Checksum (Optional)
---------------------------	------------------------

Type

FB90 **Standard**

FB91 UCC-128

The Code-128 can be translated to UCC-128 format if it starts with FNC1 character. The first FNC1 will be translated to "J1", and next to be a concatenation code as <GS>(7F₁₆).

J1	Datas	<GS>	Datas	Checksum
----	-------	------	-------	----------

Verify Checksum

FBB0 Disable

FBB1 **Enable**

The checksum is presented as the sum module 103 of all data digits.

Tx Checksum

FA60 Disable

FA61 **Enable**

Refer 26.

Truncate Zero



FA50 **Disable**

FA51 Enable

Refer 27.

Code-128

END

Refer , .

Specific Adjustments

Truncate Lead



(Range:00₁₀-FF₁₀)

Truncate End



(Range:00₁₀-FF₁₀)

Min. Length



(Range:00₁₀-FF₁₀)

Max. Length



(Range:00₁₀-FF₁₀)

Insert0 Position



(Range:00₁₀-FF₁₀)

Insert1 Position



(Range:00₁₀-FF₁₀)

Insert0 Data



(Range:00₁₆-FF₁₆ ASCII Code)

Insert1 Data



(Range:00₁₆-FF₁₆ ASCII Code)

ID



(Range:00₁₆-FF₁₆ ASCII Code)

Sub ID



(Range:00₁₆-FF₁₆ ASCII Code)

4

Code Option

ENTER



Code-93

Read

KA70 **Disable**

KA71 Enable

Format

Data Digits (Variable)	Checksum1 (Optional)	Checksum2 (Optional)
---------------------------	-------------------------	-------------------------

Verify Checksum

KBB0 Disable

KBB1 One

KBB2 **Two**

The checksum is presented as the sum module 47 of all data digits.

Tx Checksum

KA60 **Disable**

KA61 Enable

Refer 26.

Truncate Zero

KA50 **Disable**

KA51 Enable

Refer 27.

Code-93

END



Refer 27, 35.

Specific Adjustments

Truncate Lead



(Range:00₁₀-FF₁₀)

Truncate End



(Range:00₁₀-FF₁₀)

Min. Length



(Range:00₁₀-FF₁₀)

Max. Length



(Range:00₁₀-FF₁₀)

Insert0 Position



(Range:00₁₀-FF₁₀)

Insert1 Position



(Range:00₁₀-FF₁₀)

Insert0 Data



(Range:00₁₆-FF₁₆ ASCII Code)

Insert1 Data



(Range:00₁₆-FF₁₆ ASCII Code)

ID



(Range:00₁₆-FF₁₆ ASCII Code)

Sub ID



(Range:00₁₆-FF₁₆ ASCII Code)

4

Code Option

ENTER



Code-11

Read

LA70 **Disable**

LA71 Enable

Format

Data Digits (Variable)	Checksum1 (Optional)	Checksum2 (Optional)
---------------------------	-------------------------	-------------------------

Verify Checksum

LBB0 Disable

LBB1 One

LBB2 **Two**

The checksum is presented as the sum module 11 of all data digits.

Tx Checksum

LA60 **Disable**

LA61 Enable

By setting **Enable**, checksum1 and checksum2 will be transmitted by the way you set on the checksum verification.

Truncate Zero

LA50 **Disable**

LA51 Enable

Refer 27.

Code-11

END



Refer 27, 35.

Specific Adjustments

Truncate Lead	L082
(Range:00 ₁₀ -FF ₁₀)	
Truncate End	L920
(Range:00 ₁₀ -FF ₁₀)	
Min. Length	L0A2
(Range:00 ₁₀ -FF ₁₀)	
Max. Length	L0B2
(Range:00 ₁₀ -FF ₁₀)	
Insert0 Position	L0C2
(Range:00 ₁₀ -FF ₁₀)	
Insert1 Positionh	L0D2
(Range:00 ₁₀ -FF ₁₀)	
Insert0 Data	L0EB
(Range:00 ₁₆ -FF ₁₆ ASCII Code)	
Insert1 Data	L10B
(Range:00 ₁₆ -FF ₁₆ ASCII Code)	
ID	L12B
(Range:00 ₁₆ -FF ₁₆ ASCII Code)	
Sub ID	L14B
(Range:00 ₁₆ -FF ₁₆ ASCII Code)	



Code Option

ENTER



MSI/Plessey

Read

MA70 **Disable**

MA71 Enable

Format

Data Digits (Variable)	Checksum1 (Optional)	Checksum2 (Optional)
---------------------------	-------------------------	-------------------------

Verify Checksum

MBB0 Disable

MBB1 **Mod 10**

MBB2 Mod 10/10

MBB3 Mod 11/10

The MSI/Plessey has one or two optional checksum characters. The checksum is presented by 3 kinds of method as Mod 10, Mod 10/10 and Mod 11/10. The checksum1 and checksum2 will be calculated as the sum module 10 or 11 of the data digits.

Tx Checksum

MA60 **Disable**

MA61 Enable

Refer 26.

Truncate Zero

MA50 **Disable**

MA51 Enable

Refer 27.



Refer 27, 35.

Specific Adjustments

Truncate Lead	M082
(Range:00 ₁₀ -FF ₁₀)	
Truncate End	M092
(Range:00 ₁₀ -FF ₁₀)	
Min. Length	M0A2
(Range:00 ₁₀ -FF ₁₀)	
Max. Length	M0B2
(Range:00 ₁₀ -FF ₁₀)	
Insert0 Position	M0C2
(Range:00 ₁₀ -FF ₁₀)	
Insert1 Positionh	M0D2
(Range:00 ₁₀ -FF ₁₀)	
Insert0 Data	M0EB
(Range:00 ₁₆ -FF ₁₆ ASCII Code)	
Insert1 Data	M10B
(Range:00 ₁₆ -FF ₁₆ ASCII Code)	
ID	M12B
(Range:00 ₁₆ -FF ₁₆ ASCII Code)	
Sub ID	M14B
(Range:00 ₁₆ -FF ₁₆ ASCII Code)	

4

Code Option

ENTER



UK/Plessey

Read

NA70	Disable
NA71	Enable

Format

Data Digits (Variable)	Checksum1+2 (Optional)
---------------------------	---------------------------

Verify Checksum

NBB0	Disable
NBB1	Enable

Refer 26.

Tx Checksum

NA60	Disable
NA61	Enable

Refer 26.

Truncate Zero

NA50	Disable
NA51	Enable

Refer 27.



Refer 27, 35.

Specific Adjustments

Truncate Lead	N082
 (Range:00 ₁₀ -FF ₁₀)	
Truncate End	N092
 (Range:00 ₁₀ -FF ₁₀)	
Min. Length	N0A2
 (Range:00 ₁₀ -FF ₁₀)	
Max. Length	N0B2
 (Range:00 ₁₀ -FF ₁₀)	
Insert0 Position	N0C2
 (Range:00 ₁₀ -FF ₁₀)	
Insert1 Position	N0D2
 (Range:00 ₁₀ -FF ₁₀)	
Insert0 Data	N0EB
 (Range:00 ₁₆ -FF ₁₆ ASCII Code)	
Insert1 Data	N10B
 (Range:00 ₁₆ -FF ₁₆ ASCII Code)	
ID	N12B
 (Range:00 ₁₆ -FF ₁₆ ASCII Code)	
Sub ID	N14B
 (Range:00 ₁₆ -FF ₁₆ ASCII Code)	



Code Option

ENTER



Telepen

Read

<input type="radio"/> OA70	Disable
<input type="radio"/> OA71	Enable

Format

Data Digits (Variable)	Checksum (Optional)
---------------------------	------------------------

Type

<input type="radio"/> OB90	Numeric
<input type="radio"/> OB91	ASCII
<input type="radio"/> OB92	Auto Switching

A Telepen can be transmitted by **Numeric** and **ASCII** format. Characters can be mixed the both format into the Telepen barcode. By setting **Auto Switching**, data can be conversed between Numeric and Full ASCII by character <DLE>(7F₁₆) automatically.

Verify Checksum

<input type="radio"/> OBB0	Disable
<input type="radio"/> OBB1	Enable

Refer 26.

Tx Checksum

<input type="radio"/> OA60	Disable
<input type="radio"/> OA61	Enable

Refer 26.

Truncate Zero

<input type="radio"/> OA50	Disable
<input type="radio"/> OA51	Enable

Refer 27.

Telepen

END



Refer 27, 35.

Specific Adjustments

Truncate Lead	0082
 (Range:00 ₁₀ -FF ₁₀)	
Truncate End	0920
 (Range:00 ₁₀ -FF ₁₀)	
Min. Length	00A2
 (Range:00 ₁₀ -FF ₁₀)	
Max. Length	00B2
 (Range:00 ₁₀ -FF ₁₀)	
Insert0 Position	00C2
 (Range:00 ₁₀ -FF ₁₀)	
Insert1 Positionh	00D2
 (Range:00 ₁₀ -FF ₁₀)	
Insert0 Data	00EB
 (Range:00 ₁₆ -FF ₁₆ ASCII Code)	
Insert1 Data	010B
 (Range:00 ₁₆ -FF ₁₆ ASCII Code)	
ID	012B
 (Range:00 ₁₆ -FF ₁₆ ASCII Code)	
Sub ID	014B
 (Range:00 ₁₆ -FF ₁₆ ASCII Code)	

4

Code Option

ENTER



RSS14

Read

PA70 **Disable**

PA71 Enable

RSS code has a new name as : **GS1 databar**

Code Mark

PA20 **Disable**

PA21 Enable

If you want **je0** to be output, then please set up the Code Mark as **Enable**.

Application ID

PA30 **Disable**

PA31 Enable

If you want **01** to be output, then please set up the Application ID as **Enable**.

Tx Checksum

PA60 **Disable**

PA61 Enable

Refer 26.

Truncate Zero



PA50 **Disable**









PA51 Enable

Refer 27.

RSS14

END

Refer , .

Specific Adjustments	
Truncate Lead	P082
 (Range:00 ₁₀ -FF ₁₀)	
Truncate End	P092
 (Range:00 ₁₀ -FF ₁₀)	
Insert0 Position	P0C2
 (Range:00 ₁₀ -FF ₁₀)	
Insert1 Positionh	P0D2
 (Range:00 ₁₀ -FF ₁₀)	
Insert0 Data	P0EB
 (Range:00 ₁₆ -FF ₁₆ ASCII Code)	
Insert1 Data	P10B
 (Range:00 ₁₆ -FF ₁₆ ASCII Code)	
ID	P12B
 (Range:00 ₁₆ -FF ₁₆ ASCII Code)	
Sub ID	P14B
 (Range:00 ₁₆ -FF ₁₆ ASCII Code)	

4

Code Option

ENTER



RSS14 Limited

READ

QA70	Disable
QA71	Enable

Code Mark

QA20	Disable
QA21	Enable

If you want the **je0** to be output, then please set the Code Mark as **Enable**.

Application ID

QA30	Disable
QA31	Enable

If you want the **01** to be output, then please set the Application ID as **Enable**.

Tx Checksum

QA60	Disable
QA61	Enable









Refer 26.

Truncate Zero

QA50	Disable
QA51	Enable

Refer 27.

Refer 27, 35.

Specific Adjustments	
Truncate Lead	Q08Z
 (Range:00 ₁₀ -FF ₁₀)	
Truncate End	Q09Z
 (Range:00 ₁₀ -FF ₁₀)	
Insert0 Position	Q0CZ
 (Range:00 ₁₀ -FF ₁₀)	
Insert1 Positionh	Q0DZ
 (Range:00 ₁₀ -FF ₁₀)	
Insert0 Data	Q0EB
 (Range:00 ₁₆ -FF ₁₆ ASCII Code)	
Insert1 Data	Q10B
 (Range:00 ₁₆ -FF ₁₆ ASCII Code)	
ID	Q12B
 (Range:00 ₁₆ -FF ₁₆ ASCII Code)	
Sub ID	Q14B
 (Range:00 ₁₆ -FF ₁₆ ASCII Code)	

4

Code Option

ENTER

RSS14 Stacked

READ	
RA70	Disable
RA71	Enable

Code Mark	
RA20	Disable
RA21	Enable

If you want **je0** to be output, then please set up the Code Mark as **Enable**.

Application ID	
RA30	Disable
RA31	Enable

If you want **01** to be output, then please set up the Application ID as **Enable**.

Tx Checksum	
RA60	Disable
RA61	Enable

Refer 26.

Truncate Zero	
RA50	Disable
RA51	Enable

Refer 27.

RSS14 Stacked

END



Refer 27, 35..

Specific Adjustments

Truncate Lead R082



(Range:00₁₀-FF₁₀)

Truncate End R092



(Range:00₁₀-FF₁₀)

Insert0 Position R0C2



(Range:00₁₀-FF₁₀)

Insert1 Positionh R0D2



(Range:00₁₀-FF₁₀)

Insert0 Data R0EB



(Range:00₁₆-FF₁₆ ASCII Code)

Insert1 Data R10B



(Range:00₁₆-FF₁₆ ASCII Code)

ID R12B



(Range:00₁₆-FF₁₆ ASCII Code)

Sub ID R14B



(Range:00₁₆-FF₁₆ ASCII Code)

4

Code Option

ENTER



RSS Expansion

READ

SA70	Disable
SA71	Enable

Code Mark

SA20	Disable
SA21	Enable

If you want the **je0** to be output, then please set up the Code Mark as **Enable**.

Application ID

SA30	Disable
SA31	Enable



If you want the **01** to be output, then please set up the Application ID as **Enable**.

Truncate Zero

SA50	Disable
SA51	Enable

Refer 27.









RSS Expansion

Refer , 35..

END



Specific Adjustments

Truncate Lead	S082
 (Range:00 ₁₀ -FF ₁₀)	
Truncate End	S092
 (Range:00 ₁₀ -FF ₁₀)	
Insert0 Position	S0C2
 (Range:00 ₁₀ -FF ₁₀)	
Insert1 Positionh	S0D2
 (Range:00 ₁₀ -FF ₁₀)	
Insert0 Data	S0EB
 (Range:00 ₁₆ -FF ₁₆ ASCII Code)	
Insert1 Data	S10B
 (Range:00 ₁₆ -FF ₁₆ ASCII Code)	
ID	S12B
 (Range:00 ₁₆ -FF ₁₆ ASCII Code)	
Sub ID	S14B
 (Range:00 ₁₆ -FF ₁₆ ASCII Code)	



Code Option

ENTER

RSS Expansion stacked

READ

TA70 **Disable**

TA71 Enable

Code Mark

TA20 **Disable**

TA21 Enable

If you want to output the **je0**, then please set up the Code Mark as **Enable**.

Application ID

TA30 **Disable**

TA31 Enable

If you want to output the **01**, then please set up the Appliation ID as **Enable**.

Truncate Zero

TA50 **Disable**

TA51 Enable

Refer □ 27.

RSS Expansion Stacked

END



Refer 27, 35..

Specific Adjustments

Truncate Lead	T082
(Range:00 ₁₀ -FF ₁₀)	
Truncate End	T092
(Range:00 ₁₀ -FF ₁₀)	
Insert0 Position	TOC2
(Range:00 ₁₀ -FF ₁₀)	
Insert1 Positionh	TOD2
(Range:00 ₁₀ -FF ₁₀)	
Insert0 Data	TOEB
(Range:00 ₁₆ -FF ₁₆ ASCII Code)	
Insert1 Data	T10B
(Range:00 ₁₆ -FF ₁₆ ASCII Code)	
ID	T12B
(Range:00 ₁₆ -FF ₁₆ ASCII Code)	
Sub ID	T14B
(Range:00 ₁₆ -FF ₁₆ ASCII Code)	

4

Code Option

ENTER



Preamble/Postamble

Tx Preamble

8C60 Disable

8C61 **Enable**

By setting **Enable**, Preamble will be appended in front of the barcode. Refer to String Output Flowchart on 5.

Preamble Data

830D Data

(Range:00₁₆-FF₁₆ ASCII Code)

There is One control digit can be programmed as Preamble. It will be appended automatically when each barcode is decoded.

Tx Postamble

8C70 Disable

8C71 **Enable**

By setting **Enable**, Postamble will be appended after the barcode. Refer to String Output Flowchart on 5.

Postamble Data

838D Data

(Range:00₁₆-FF₁₆ ASCII Code)

Generally, your application need to append a carriage return character to finish data transmission. Or you may set the Postamble to be **Disable** to have your application without any control characters appended after data transmission. The factory default of **Postamble Data** is <CR>(0D₁₆) and <LF>(0A₁₆).

Example Append the code "@+" after each barcode transmitted.

- 1) **ENTER** → Entry Programming
- 2) **Enable** → Enable Postamble Transmission
- 3) **Data** → 4 → 0 → **SET** → Postamble Data "@"
"@"
- 4) **END** → Exit Programming

ENTER



Memory

Tx. Header	
7A00	Disable
7A01	Enable

The option enables to display the header information while uploading the barcode data from the flash memory.

Tx. Date & Time	
7A10	Disable
7A11	Enable

The option enables to display the date and time while uploading the barcode data from the flash memory

Reject Same	
7A20	Disable
7A21	Enable

The option enables to reject the same barcode data scanned.
This option is only available when the trigger mode is set to "Continue"

Good Read Beep	
7A60	Disable
7A61	Enable

This option enables the Beep sound when the barcode data is successfully read

Good Read Vibrator	
7A70	Disable
7A71	Enable

If set **Enable**, the Scanner Vibrates when successfully read a barcode.
This function is only applicable in CM 200 series. For CM 500 series, vibration motor is an extra purchase option.

Time Format	
7B90	hh:mm:ss
7B91	hh:mm

The options of time display

Memory

The options of date display.

END

Date Format	
yyyy/mm/dd	7BD0
mm/dd/yyyy	7BD1
yy/mm/dd	7BD2
mm/dd/yy	7BD3
yyyy-mm-dd	7BD4
mm-dd-yyyy	7BD5
yy-mm-dd	7BD6
mm-dd-yy	7BD7
dd/mm/yyyy	7BD8
dd/mm/yy	7BD9
dd-mm-yyyy	7BDA
dd-mm-yy	7BDB

6

Memory

ENTER



Memory

Specific Adjustments

7042	Ext. Tx Delay
(Range:00 ₁₀ -FF ₁₀ Unit:10ms)	
7052	Lamp Off delay
(Range:00 ₁₀ -FF ₁₀ Unit:1s)	
7062	Standby Time
(Range:00 ₁₀ -FF ₁₀ Unit:1s)	
707A	Separator
(Range:00 ₁₆ -FF ₁₆ ASCII Code)	

Ext Tx Delay:

This option enables to add delay time in each barcode data upload to PC. **Default:0ms, Max:2550ms.**

This is only applicable in CM200, and CM500 series models.

Lamp Off Delay: This enables to set the duration time of laser beam power on, the laser beam will automatically turn off if barcode label not scanned. This setting is only available when the trigger mode is set as "good read off" or "Timeout Off". **Default: 5 Sec.**

Standby Time: When the light source turns off, this function enables to set the time to turn off the main power of the scanner. **Default: 0 sec.**

Separator: The separator setting of date, time, and the barcode data when uploading the barcode data from flash memory.





Memory



6

Memory

Bluetooth

BT Module Enter	/\$%BTM 	In order to set up the Bluetooth option, "BT module Enter" must be scan first.
Local Name	ZBT1 	This option enables the user to assigned the scanner name. Please refer to the HEX ASCII table (Form 0~9, A~F). The first digit and last digit cannot be space or "-". If scanner name setting is incorrect, connection failure will occur.
Remote Mac address	ZBT2 	Options of Mac address setting, total of 12 digits, Please refer to the HEX ASCII table (From 0~9, A~F). (1) If scanner connection mode is set as "Slave", Scanner address can be set as 12 digits of "0" to connect with any types of Bluetooth devices. OR scanner address can be assigned with appointed Bluetooth device MAC address to connect with that particular Bluetooth device.] (2)If scanner connection mode is set as "Master" scanner address must assign as appointed Bluetooth device MAC address. And it cannot be set As 12 digits of "0".
Pin Code	ZBT3 	Pin code password setting for scanner connection. Default is "1234"

Bluetooth

END



Mode

Bluetooth connection Mode

Please refer to page 82 to scan the numbers to switch different mode.

- 0:Slave
- 1:Master
- 2:HID

Procedure:

- 1) scan "BT module Enter"
- 2) scan " Mode"
- 3) scan 0 or 1 or 2 to switch mode (page 76).
- 4) scan **Set**
- 5) scan **END**

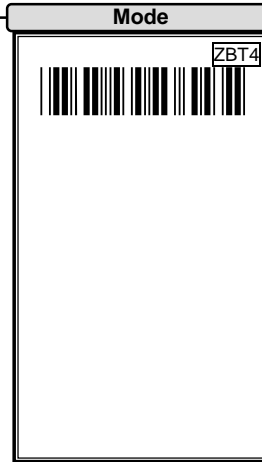

Default

Bluetooth setting reset to **Default**.



LIST

List function will display the parameters of the Bluetooth setting. For example, the values of Local Name, Remote Mac address, Pin Code, Mode.

Display values as following:

Serial Adaptor (Local Name)
00126F006E9B (Mac Address)
1234 (Pin Code)
0 (Mode)



Bluetooth

Note:

1. When pairing in progress, pressing the pairing button again will cancel the current pairing progress.
2. When resetting the connection of Slave/ Master mode, user must re-pairing with the bluetooth device for rest changes.
3. When Blue LED flashing quickly, it means resetting the changes to the scanner.
4. When Blue LED flashing slowly, it means pairing progress waiting.
5. When Connection mode is set as "Slave", pairing process must be accomplish in 60 seconds. Otherwise, connection failure will occur.

ENTER



Wireless

Good Read Beep

6A60 Disable

 6A61 **Enable**

This option enables the Beep sound when the barcode data is successfully read

Good Read Vibrator





6A70 Disable

 6A71 **Enable**

If set **Enable**, the Scanner Vibrates when successfully read a barcode.

This function is only applicable in CM 200 series. For CM 500 series, vibration motor is an extra purchase option.

Specific Adjustments

6042 Connect Off Time

 (Range:00₁₀-FF₁₀ Unit:1s)
 6052 Lamp Off delay

 (Range:00₁₀-FF₁₀ Unit:1s)
 6062 Standby Time

 (Range:00₁₀-FF₁₀ Unit:10s)
 6072 Timeout

 (Range:00₁₀-FF₁₀ Unit:1s)

Connect Off Time: This enables to set the duration timing into sleep mode, while wireless connection status is successfully connected. **Default 60 Sec**

Lamp Off Delay: This enables to set the duration time of laser beam power on, the laser beam will automatically turn off if barcode label not scanned. This setting is only available when the trigger mode is set as "good read off" or "Timeout Off". Default: 5 Sec.

Standby Time: When the light source turns off, this function enables to set the time to turn off the main power of the

scanner. Default: 0 sec.

Timeout: the timeout setting for the handshaking acknowledgment from the host PC. If scanner did not receive acknowledgement from the host PC, the warning sound will be active. The function is particular useful for some application which the host PC will take longer response time. **Default: 10 Sec.**

Wireless



8

Wireless

Special Setting For CM500 series

Send Barcode data



PC .

In Bluetooth mode or connecting with USB cable, scan this barcode will transmit the saved barcode data in the memory to

Clear barcode data



Under any operation mode, scan this barcode will erase all the barcode data saved in the memory.

Bluetooth to Memory



For CM500 Three in one function model, you can scan this barcode to switch from Bluetooth mode to Memory mode without pressing the Scan key for mode switching.

Memory to Bluetooth



For CM500 Three in one function model, you can scan this barcode to switch from Memory mode to Bluetooth mode without pressing the Scan key for mode switching.

Cable Type

IBM PC, XT, AT & PS/2		
Function	6p Mini Din(M)	6p Mini Din(F)
Clock (Host)	5	---
Data (Host)	1	---
Clock (KBD.)	---	5
Data (KBD.)	---	1
Ground	3	3
GND Shield	3	3
VCC (+5V)	4	4

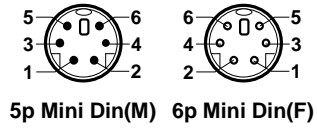

RS-232		
Function	9p D-Sub(F)	DC Jack(M)
TxD	2	...
RxD	3	...
RTS	8	...
CTS	7	...
Shorted	4,6	...
Ground	5	2
GND Shield	5	2
VCC (+5V)	9	1

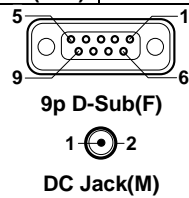

Test Chart

UPC-A



EAN-13 (ISBN) with Add-on 5



Code-39 (Full ASCII Code)



Interleaved 2 of 5



Code-93



Code-128 (C Type)



Test Chart

MSI/Plessey



1 0 5 5 8 3 0 2 5

Telepen



T E L E P E N T e s t +
(Numeric: 57424942534251055774888916)

RSS14



(01)20012345678909

RSS Expansion Stacked



(01) 0 0614141 00001 2

PDF417



















PDF417Test

ASCII Code Table

H L	0 (*)	1 (*)	0	1
0	Null		NUL	DLE
1	Up	F1	SOH	DC1
2	Down	F2	STX	DC2
3	Left	F3	ETX	DC3
4	Right	F4	EOT	DC4
5	PgUp	F5	ENQ	NAK
6	PgDn	F6	ACK	SYN
7		F7	BEL	ETB
8	Bs	F8	BS	CAN
9	Tab	F9	HT	EM
A		F10	LF	SUM
B	Home	Esc	VT	ESC
C	End	F11	FF	FS
D	Enter	F12	CR	GS
E	Insert	Ctrl+	SO	RS
F	Delete	Alt+	SI	US

(*) For keyboard wedge only.

H L	2	3	4	5	6	7
0	SP	0	@	P	`	p
1	!	1	A	Q	a	q
2	“	2	B	R	b	r
3	#	3	C	S	c	s
4	\$	4	D	T	d	t
5	%	5	E	U	e	u
6	&	6	F	V	f	v
7	'	7	G	W	g	w
8	(8	H	X	h	x
9)	9	I	Y	i	y
A	*	:	J	Z	j	z
B	+	;	K	[k	{
C	,	<	L	\	l	
D	-	=	M]	m	}
E	.	>	N	^	n	~
F	/	?	O	_	o	DEL

0		%00
1		%01
2		%02
3		%03
4		%04
5		%05
6		%06
7		%07
8		%08
9		%09
A		%0A
B		%0B
C		%0C
D		%0D
E		%0E
F		%0F
SET		%OK